

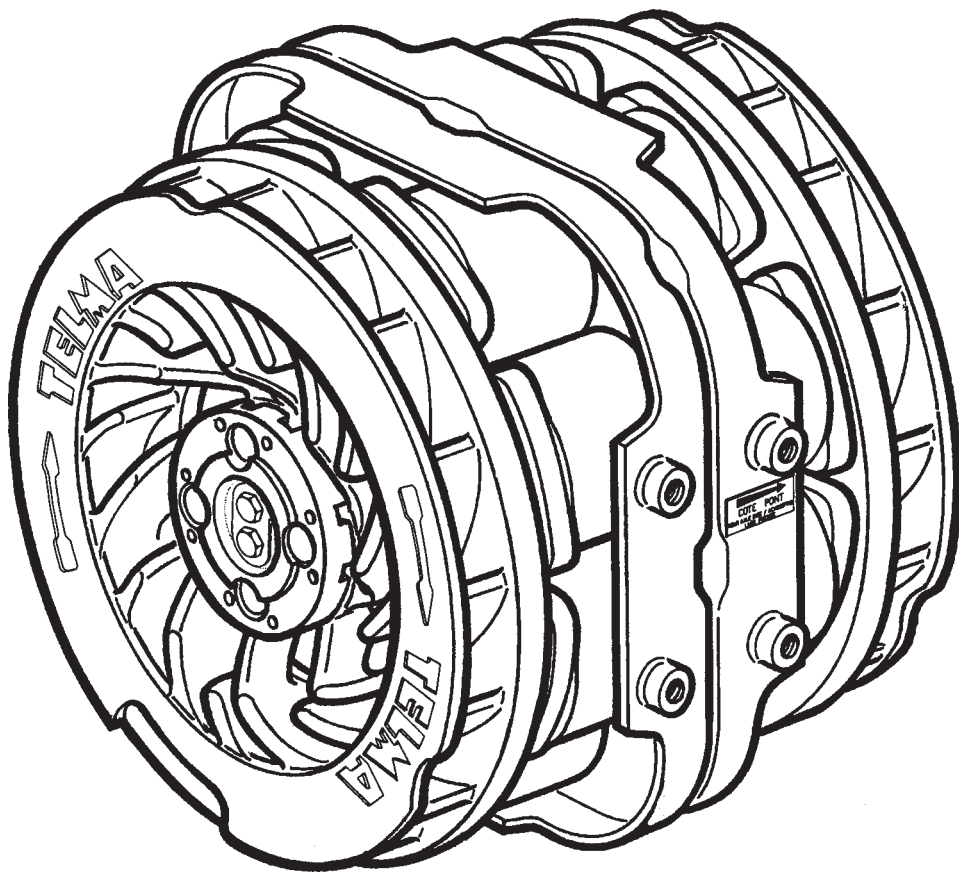

## *TECHNICAL SPECIFICATIONS*



### *AC 61 – 60 Retarder*

**Identification**

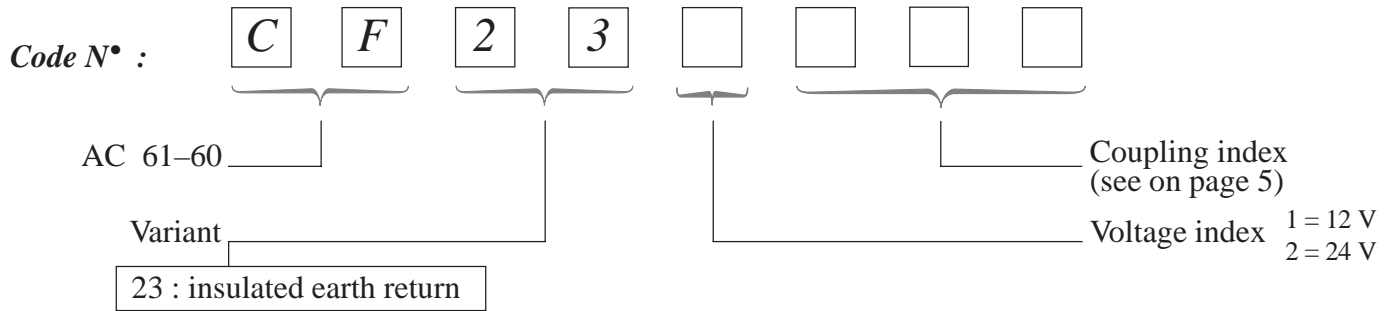

**Specifications**

MASS	Total : 229 kg 505 lb	Rotors : 67 kg 148 lb	Stator : 162 kg 357 lb
RANGE of application * G.C.W.	15 / 19 metric tons		
Maximum BRAKING TORQUE	1600 Nm / 1179 lb-ft		
Rotors INERTIA	1.82 kgm <sup>2</sup> / 43.18 lb-ft <sup>2</sup>		
Maximum ROTATIONAL SPEED	4000 min <sup>-1</sup>		
Maximum TRANSMISSIBLE TORQUE	12800 Nm / 9430 lb-ft		

\* for specific applications, consult our Technical Department

**Curves**

**TORQUE**  
1-2-3-4 : control stages

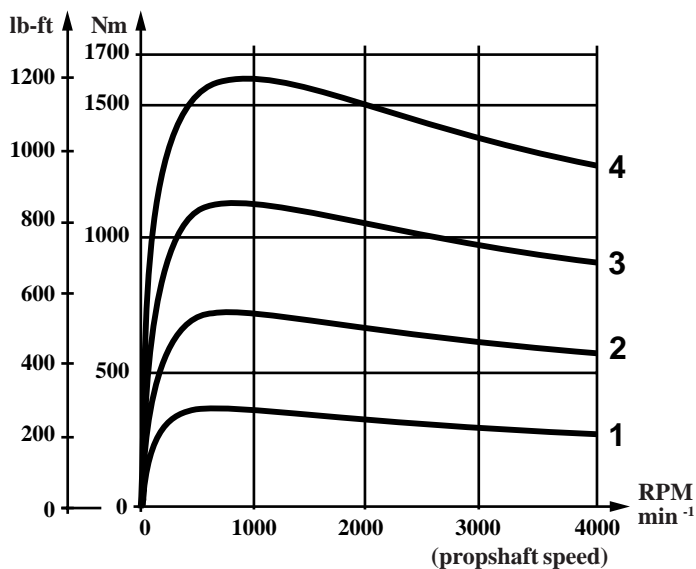

**POWER**

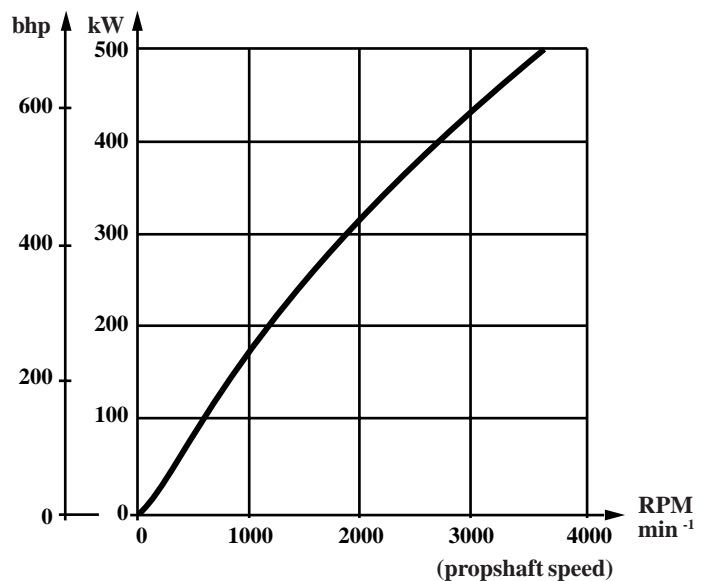

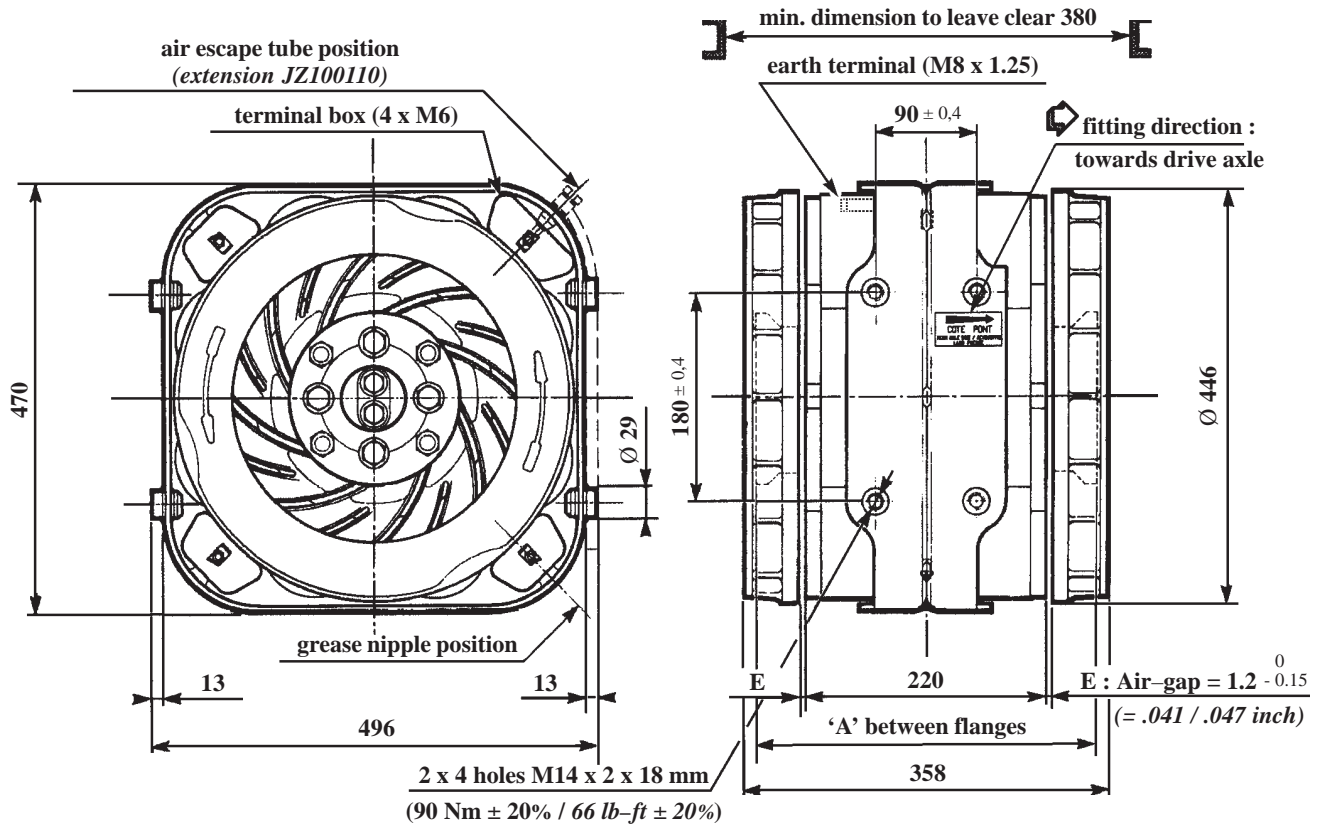

NOTE : all the dimensions are given in millimeters 1 mm = .039 inch

## Cross-section view

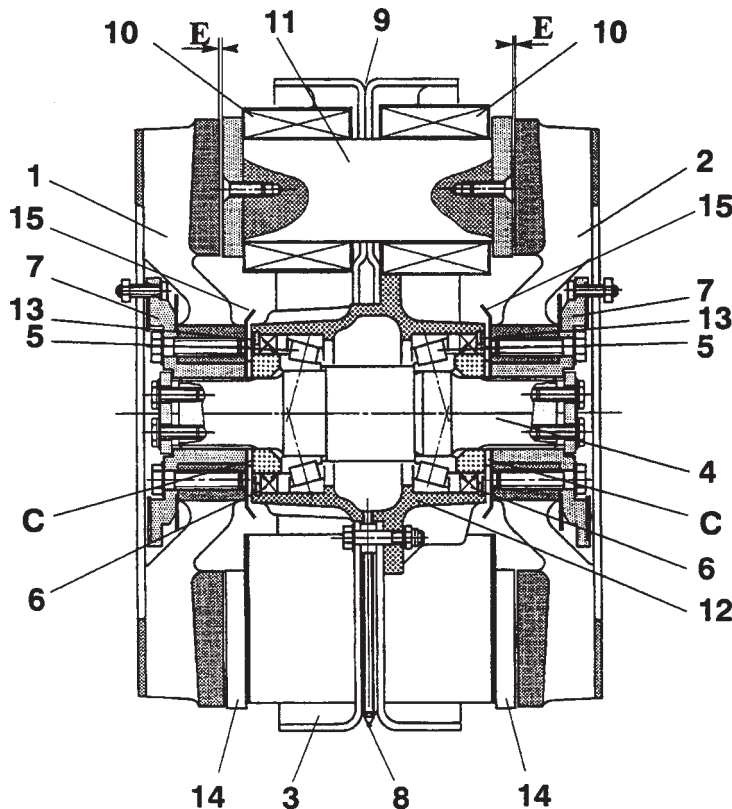

- E – Air-gap
- C – Air-gap adjusting shims
- 1 – Front rotor
- 2 – Rear rotor (axle side)
- 3 – Stator
- 4 – Shaft
- 5 – Bearing
- 6 – Seal with double lip
- 7 – Coupling flange
- 8 – Grease nipple
- 9 – Air escape tube  
Air escape tube extension JZ100110  
(to be ordered separately)
- 10 – Coil
- 11 – Pole
- 12 – Hub
- 13 – Circlips
- 14 – Pole shoe
- 15 – Deflector



Cross-section views

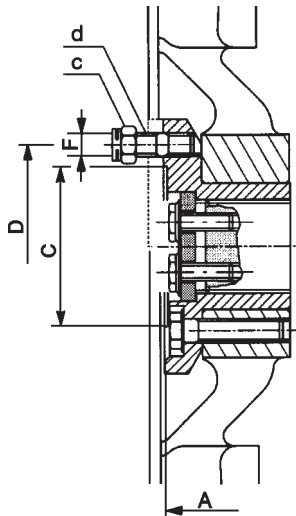

indexes 105/155

Figure 1

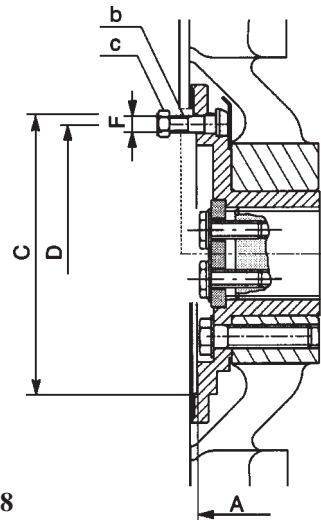

indexes 106/158

Figure 2

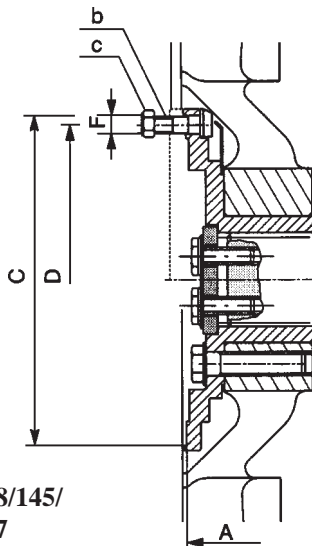

indexes 107/108/145/  
152/157

Figure 3

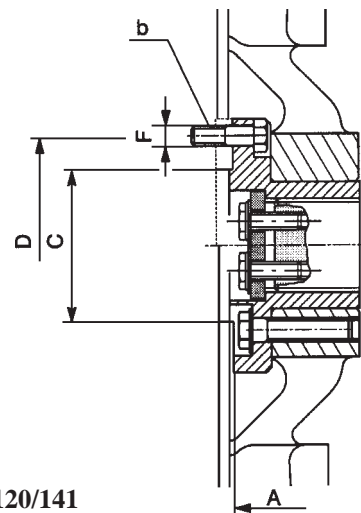

indexes 117/120/141

Figure 4

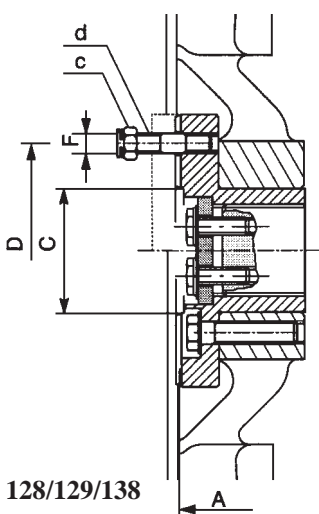

indexes 128/129/138

Figure 5

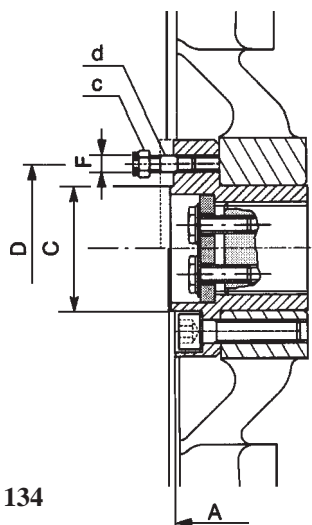

index 134

Figure 6

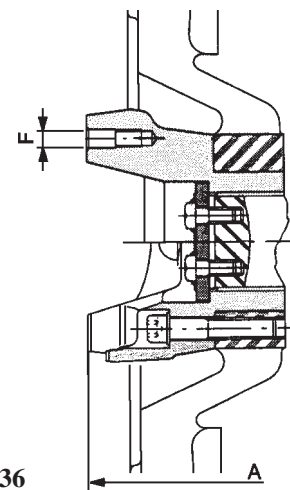

index 136

Figure 7



## Specifications

A	C	D	E	F	SUPPLIED FASTENERS	Fig.	Rotor securing	
							4 screws	5 screws
<i>index 105 : SAE 1500 – metric thread</i>						<i>Ref. 24 V : CF232105</i>		
332	95.26	120.67	4	M14x1.50	studs (d) nuts (c)	1	x	
<i>index 106 : SAE 1600 – metric thread</i>						<i>Ref. 24 V : CF232106</i>		
329	168.25	155.52	8	M10x1.00	screws (b) nuts (c)	2	x	
<i>index 107 : SAE 1700 – metric thread</i>						<i>Ref. 12 V : CF231107</i>		
332.2	196.85	184.12	8	M10x1.00	studs (d) nuts (c)	3	x	
<i>index 108 : SAE 1800 – metric thread</i>						<i>Ref. 24 V : CF232108</i>		
332.2	196.85	184.12	12	M11x1.50	studs (d) nuts (c)	3	x	
<i>index 117 : DIN Ø 150 mm</i>						<i>Ref. 24 V : CF232117</i>		
332	90	130	8	M12x1.50	screws (b)	4	x	
<i>index 120 : DIN Ø 180 mm</i>						<i>Ref. 24 V : CF232120</i>		
332	110	155.5	8	M14x1.50	screws (b)	4	x	
<i>index 128 : Ø 120 mm cross – serration</i>						<i>Ref. 24 V : CF232128</i>		
336		100	4	M10x1.00	studs (d) nuts (c)	5	x	
<i>index 129 : Ø 150 mm cross – serration</i>						<i>Ref. 24 V : CF232129</i>		
336		130	4	M12x1.50	studs (d) nuts (c)	5	x	
<i>index 134 : DIN Ø 120 mm</i>						<i>Ref. 24 V : CF232134</i>		
339	75	101.5	8	M10x1.25	studs (d) nuts (c)	6	x	
<i>index 136 : P400 SCANIA</i>						<i>Ref. 24 V : CF232136</i>		
483.4		131.9x66	4	M12x1.75			7	x
<i>index 138 : Ø 180 mm cross – serration</i>						<i>Ref. 24 V : CF232138</i>		
336		150	4	M14x1.50	studs (d) nuts (c)	5	x	
<i>index 141 : DIN Ø 165 mm</i>						<i>Ref. 24 V : CF232141</i>		
332	95	140	8	M16x1.50	screws (b)	4	x	
<i>index 145 : SAE 1700 reinforced – metric thread</i>						<i>Ref. 24 V : CF102145</i>		
332.2	196.85	184.12	12	M10x1.00	screws (b) nuts (c)	3	x	
<i>index 152 : SAE 1700 – british/american thread</i>						<i>Ref. 12 V : CF231152</i>		
332.2	196.85	184.12	8	9.52	3/8" 24 UNF screws (b)	3	x	
<i>index 155 : SAE 1480/1550 – british/american thread</i>						<i>Ref. 12 V : CF231155</i>		
332	95.26	120.67	4	12.7	1/2" 20 UNF studs (d) nuts (c)	1	x	
<i>index 157 : SAE 1800 – british/american thread</i>						<i>Ref. 12 V : CF231157</i>		
332.2	196.85	184.12	12	11.1	7/16" 20 UNF screws (b) nuts (c)	3	x	
<i>index 158 : SAE 1550/1610 – british/american thread</i>						<i>Ref. 12 V : CF231158</i>		
332.2	168.25	155.52	8	9.52	3/8" 24 UNF screws (b)	2	x	

A – Distance between both coupling flanges or between both SCANIA universal joints (see on page 3)

C – Centering diameter

D – Pitch circle diameter or distance between the securing holes on SCANIA coupling

E – Number of securing screws

F – Specifications of the securing screws

NOTE : For all other couplings, please consult our Technical Department.  
All the dimensions are given in millimeters 1 mm = .039 inch

VOLTAGE (according to vehicle equipment)	12 V	24 V
Voltage INDEX	1	2
RESISTANCE per CIRCUIT ( $\pm 5\%$ ) at 20 °C (68 °F)	0.19 $\Omega$	0.75 $\Omega$
RESISTANCE per COIL ( $\pm 5\%$ ) at 20 °C (68 °F)	0.75 $\Omega$	
INSULATION RESISTANCE	> 1 M $\Omega$	
Nominal average AIR-GAP	1.2 <sup>0</sup> <sub>-0.15</sub> mm (.041 / .047 inch)	

### 12 V specifications

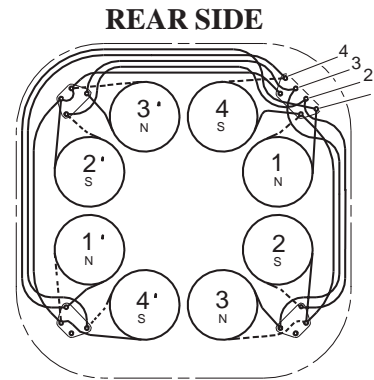
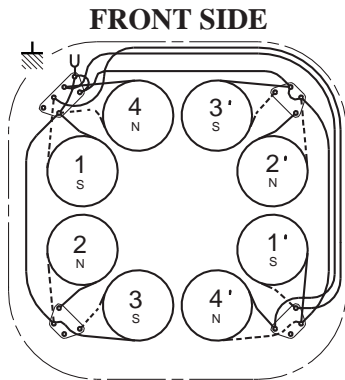

— red sleeve  
 - - - blue sleeve

**CURRENT CONSUMPTION**  
 (at 20 °C (68 °F) according to control stage)

STAGE	1	2	3	4
CURRENT $\pm 5\%$ (A)	63	126	189	252

**LAYOUT OF ONE STAGE**

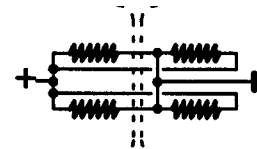

### 24 V specifications

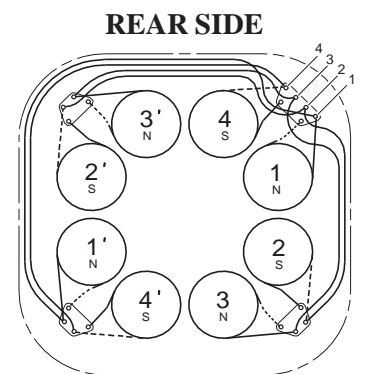
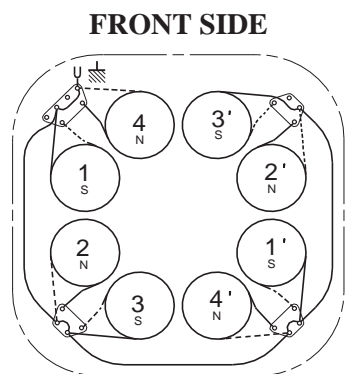

— red sleeve  
 - - - blue sleeve

**CURRENT CONSUMPTION**  
 (at 20 °C (68 °F) according to control stage)

STAGE	1	2	3	4
CURRENT $\pm 5\%$ (A)	31.5	63	94.5	126

**LAYOUT OF ONE STAGE**

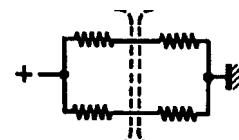



## Fitting example

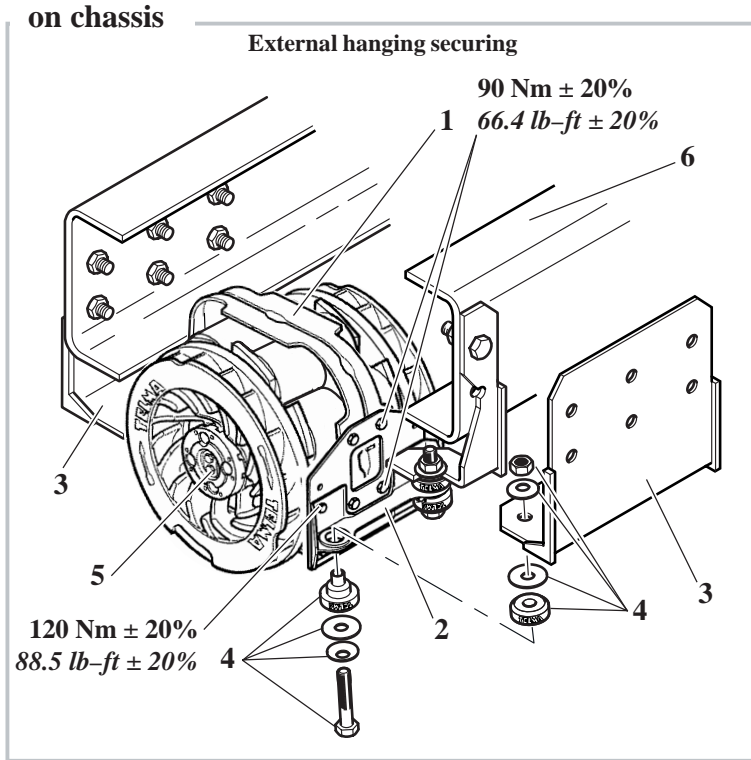

- 1 – Retarder
- 2 – Set of 2 side – plates
- 3 – Set of 2 consoles (JZ100743)
- 4 – Set of 4 rubber mounts with fasteners (230 Nm/169.6 lb-ft)
- 5 – Coupling flange
- 6 – Chassis

## Wiring diagram (example with hand control)

Consult our Technical Department for automatic control and governing devices (ex. : ABS ...)

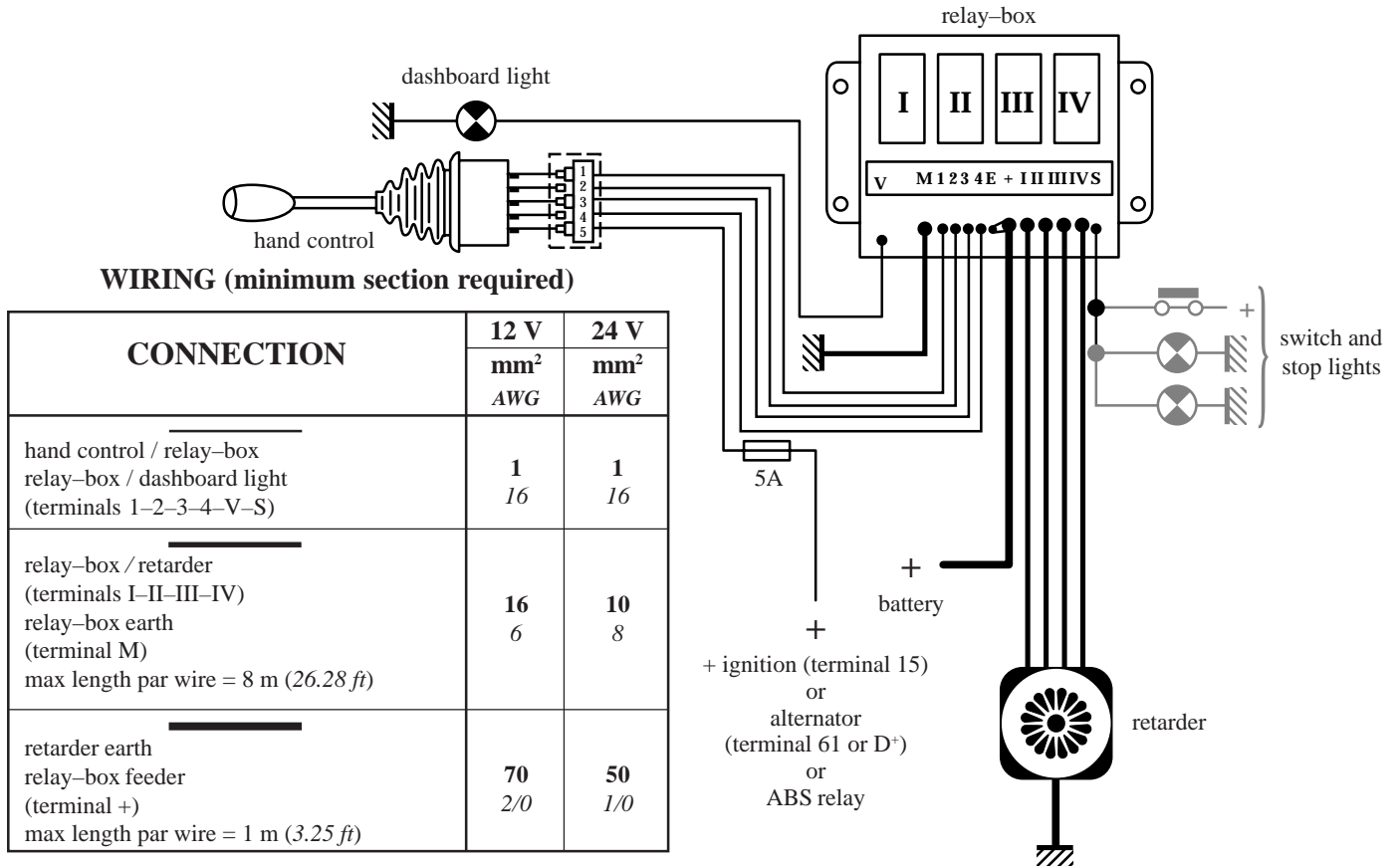

NOTE : for longer lengths, please consult our Technical Department.



28, rue Paul Painlevé – Z.A. du Vert Galant  
F – 95310 SAINT OUEN L'AUMONE – FRANCE  
B.P. 692 – F – 95004 CERGY Cedex – FRANCE  
Tel. (33) (0) 1 34 48 54 00 – Fax : (33) (0) 1 30 37 63 69

LABINAL S.A. au capital de 410 757 700 FRF  
Siège Social : 5 avenue Newton – 78180 Montigny-le-Bretonneux  
552 139 305 R.C.S. Versailles – N° d'identification TVA FR 46 552 139 305

GRUPE LABINAL  
DIVISION RALENTISSEURS TELMA 

*This technical data is supplied for your guidance in the use of the product and may be modified at any moment without prior notice.*

*Any reproduction, duplication or translation of this publication, also in the form of an abstract, is subject to the previous written permission of LABINAL, TELMA Retarders Division, Cergy.*

*Printed in France*